

# METRO-HYBRID

## LIGHTING TOWER



### Performance

Mast Max. Elevation	9.00 m
Height Stowed	2.40 m
Length Stowed	
Drawbar in Transport Position	2.25 m
Drawbar in Towing Position	2.90 m
Stowed Width	1.75 m
ATM	1150 kg
GTM	1030 kg
Length with Outriggers Extended	2.34 m
Width with Outriggers Extended	2.15 m
Wind Speed Rating	100 km/hr

### Standard Specifications

#### Power

Engine	Kubota Z482-E4B
Engine Emission	Level Tier 4 Final
Fuel Type	Diesel
Fuel Consumption (litre per hour)	1.4 L/hr
Recharge Time from 80% DOD (Depth of Discharge)	2.5 hours
Generator	52 V 3-phase PMG
Battery	1 x 205 A hr Lithium (LiFePO <sub>4</sub> )
Battery Run Time (before Recharge)	11 Hours (100% light output to 70% DOD , 25% light output from 70% to 80% DOD)
Lights	LED
Colour Temperature	5700 K
Light Power	4 x 200 W
Luminous Output	160,000 lm
Control System	Fully Integrated PLC System
Noise Level @ 7m radius	<65 dB(A)
Fuel Tank Capacity	100 L

#### Travel

Wheels	Sunraysia Style 14"x6J
Tyres	185R14C
Towing Speed (maximum)	80 km/ hr

#### Mast System

Lift	Hydraulic
Mast Lift Time	25 seconds
Mast Lower Time	13 seconds
Lighthouse Tilt	50° Electro Mechanical
Lighthouse Rotate	116° (+58°/-58°)
Hydraulic System Pump	
Voltage	12 V DC
Pressure	240 bar (3500psi)
Flow Rate	0.78 cm <sup>3</sup> /rev
Function Control	Electric over Hydraulic



### Standard Features

- Telematics
- Electronic Module including Auto-Start and Advanced Engine Management
- External Emergency Stop
- Moulded Hoods
- Bunding for all Fluids (110%)
- Forklift Tyne Pockets
- Crane Lifting Point
- Folding Drawbar
- Long Extension Wind Down Outriggers
- 50° Light Head Tilt
- 116° Rotation of Light Head
- Torsion Independent Axle
- Cable Mechanical Disc brakes
- Sunraysia Style Rims
- LED Trailer Traffic Lights
- 7 Pin Flat Trailer Plug

### Accessories & Options

- Battery Isolator Lockable
- Battery Isolator LockSafe
- Handbrake Mast Release
- Starter Isolator Lockable
- Starter Isolator LockSafe
- Spark Arrestor Muffler
- Burst Protection On Hydraulic Hosing
- Jump Start Receptacle
- Wheel Chocks
- 4.5 kg Fire Extinguisher
- Rotating Amber Beacon or Strobe Light

# METRO-HYBRID

## LIGHTING TOWER



### Dimensions

All dimensions are approximate.

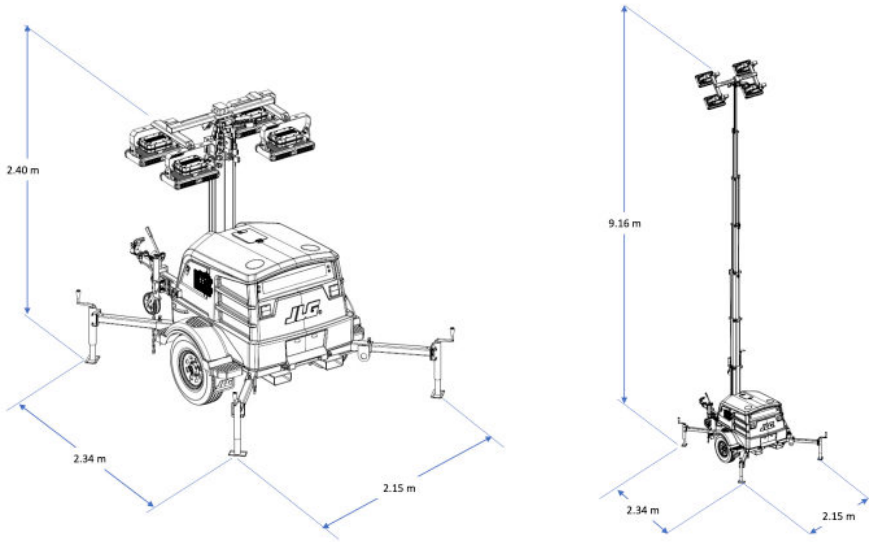

### Isolux Plot

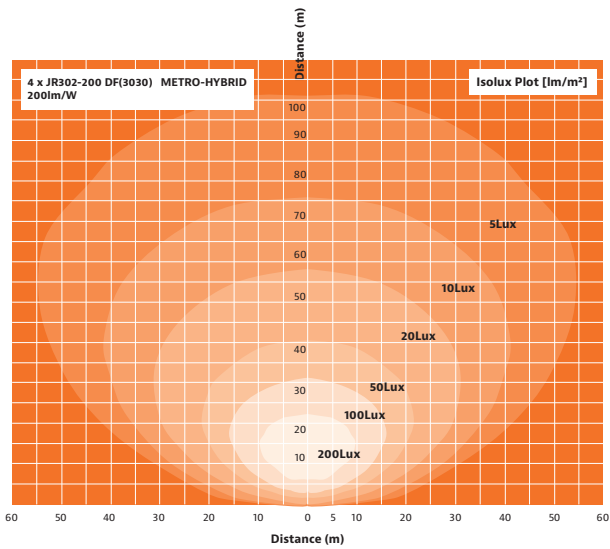

### The JLG "1 & 5" Warranty

The JLG "1 & 5" Warranty JLG Industries, Inc. backs its products with its exclusive "1 & 5" Warranty. We provide coverage on all products for one (1) full year and cover all specified major structural components for five (5) years. Due to continuous product improvements, we reserve the right to make specification and/ or equipment changes without prior notification.

R0325

**JLG Industries (Australia)**  
 358 Park Road  
 Regents Park, NSW 2143  
 Telephone 02 8718 6300  
 Fax 02 8718 6377  
[www.jlg.com.au](http://www.jlg.com.au)

**An Oshkosh Corporation Company**