

ERT3369

ELECTRIC POWERED ROUGH TERRAIN SERIES

SCISSOR LIFT



KEY SPECS

Platform Height

32-ft 8-in / 10-m

Machine Width

69.3-in / 1.76-m

Platform Capacity

1,000-lb / 453.59-kg

Stowed Drive Speed

3.5 mph / 5.6 kph

KEY FEATURES

- Our electric powered rough terrain models offer drive capability at full height, limiting unnecessary trips up and down for working professionals.
- This machine utilizes higher part commonality and a maintenance-free 2WD AC drive system for simplified service across the rough terrain family.
- As the largest platform size in its class, you can bring more operators and tools to the job.
- Delivers the latest technology, featuring an LCD platform control box with LiftSense technology and USB charging for next-level, real-time productivity and service communication to the operator.

ACCESSORIES & OPTIONS

- 26 x 12-in Foam Filled Lug Tread Tires
- ClearSky™
- Dual Flashing Amber Beacons - LED
- 8 x 6V, 310 Amp Hr
- Flashing Amber Beacon - LED
- Generator Set (Kubota Stage V OC60-E4) 6hp (4.5kW)
- Heavy Duty Pipe Racks
- Hydraulic Leveling Jacks (Auto Level)
- JLG CleanGuard
- Operator Access Control
- Special Hydraulic Fluids
- Special Paint
- White Noise Backup Alarm

STANDARD SPECIFICATIONS

Performance	Indoor	Outdoor
Platform Height-Elevated	32-ft 8-in / 10-m	32-ft 8-in / 10-m
Platform Height-Lowered	4-ft 9-in / 1.5-m	4-ft 9-in / 1.5-m
Platform Capacity	1,000-lb / 453.59-kg	1,000-lb / 453.59-kg
Capacity on Platform Extension	300-lb / 136-kg	300-lb / 136-kg
Number of Occupants	4	2
Lift / Lower Time	44/40 seconds	44/40 seconds
Maximum Drive Height	Fully Elevated	Fully Elevated
Weight w/One Extension*	9,457-lb / 4,284-kg	9,457-lb / 4,284-kg
Drive Speed-Lowered	3.5 mph / 5.6 km/h	3.5 mph / 5.6 km/h
Drive Speed-Raised	0.5 mph / 0.8 km/h	0.5 mph / 0.8 km/h
Gradeability	35%	35%
Max Tilt Rating - Side-to-Side	2.5 Degrees	2.5 Degrees
Max Tilt Rating - Fore and Aft	3 Degrees	3 Degrees
Turning Radius - Inside	83-in / 2-m	83-in / 2-m
Turning Radius - Outside	175-in / 4-m	175-in / 4-m

* Certain options or country standard will increase weight.

Power Source

Drive (2WD) AC Electric Drive

Tires

Non-Marking 26-in x 12-in Foam-filled

Hydraulic System

Capacity 13.2 gal. / 50 L

STANDARD FEATURES

- 110V-AC Receptacle In Platform
- 2WD AC Drive System
- 23 Amp Automatic, SCR Battery Charger
- 26 x 12-in Foam Filled Non-Marking Tires
- 42-in Roll-out Deck Extension
- 8 x 6V, 225 Amp Hr
- All Motion Alarm
- Descent Alarm
- Full Time Traction Control
- Horn
- Hourmeter
- LCD Display with LiftSense System
- Lubrication-Free Scissor Arm Bushings
- Manual Descent Pull Cable†
- Moveable, Removable Platform Console Box
- Nickel Plated Pins, Yellow Zinc-Chromate Plated Fasteners
- Oscillating Front Axle
- Pin-Less Fold Down Rail System
- Pin-based Load Sensing System
- Platform Control Box with LCD Display, USB Charger and Phone Holster
- Proportional Lift and Drive
- Self-closing Gate
- Scissor Maintenance Prop
- Telematics-Ready Harness
- Tie Down Lugs

ERT3369

ELECTRIC POWERED ROUGH TERRAIN SERIES

SCISSOR LIFT



DIMENSIONS

All dimensions are approximate

Dimensions

All dimensions are approximate.

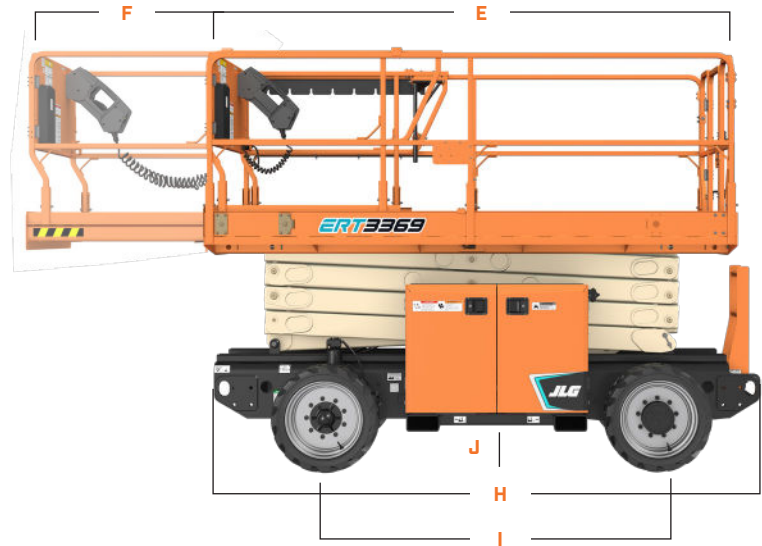
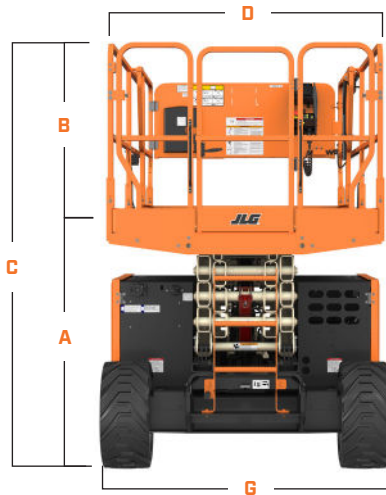

A. Platform Height – Lowered	4-ft 9-in / 1.46-m
B. Platform Railing Height	44.7-in / 1.14-m
C. Machine Height	8-ft 7-in / 2.61-m
D. Platform Width	63-in / 1.6-m
E. Platform Length	130.5-in / 3.3-m

F. Platform Extension	42-in / 1.07-m
G. Machine Width	69.3-in / 1.76-m
H. Machine Length	139-in / 3.53-m
I. Wheelbase	81.3-in / 2.07-m
J. Ground Clearance	9.5-in / 24-cm



We provide coverage for one (1) full year, and cover all specified major structural components for five (5) years. Due to continuous product improvements, we reserve the right to make specification and/or equipment changes without prior notification. This machine meets or exceeds applicable ANSI and CSA requirements based on machine configuration as originally manufactured for intended applications. Please reference the serial number plate on the machine for additional information.



JLG INDUSTRIES, INC.
Toll-free US 877-JLG-LIFT
JLG.com

An Oshkosh Corporation Company